



UL Ti MATE 80 Extended 'submersible through hull light'

'Xenon' with 55 watt Ballast



LAMP TYPE - XENON DISCHARGE 55 WATT

ORDERING NO FOR 12 VOLT - S02652-XT-V6W5 & 24 VOLT - S02652-XT-V5W5

- **UL Ti MATE 80 Extended Installation (Maximum hull thickness 120mm) and Operation instructions.**
- Qualified/Approved personnel must be used to carry out installation
- Before cutting a hole in the hull, check the hull wall thickness is not greater than 120mm. The location of the holes must be below the waterline. After cutting and finishing the hole surface, check the 60mm diameter. UL Ti MATE 80 'body' (9) can be inserted.
- Note for cored hulls - After cutting, the exposed surfaces of the hole must be finished to form a solid surface through it. Thus protecting the internal core of the hull. The wall thickness of the hole should not to less than 5mm-0.25inch. Apply 3M-4200FC sealant to the 'body' (9) flange. Slide the body into the hole and from inside the hull put the 'compensating ring' (10) on and screw the 'case securing ring' (11) up hand tight. Gently tighten the adjustment screws (6) so the compensating ring is flush to the hull and the sealant has flowed completely around the flange and hull. Do **NOT** overtighten the bolts as this will squeeze the sealant from the surfaces. Allow the sealant to solidify and remove surplus. Finally tighten the bolts to 4Nm. / 3ft. lbs.
- **Note: Maximum ambient operating temperature is 55C/131F of the ballast**
- The ballast must be installed a minimum of **24 inches (600 mm)** above the bilge. Fit the 'lamp' (5) and assemble the remaining parts to the 'through-hull' submersible marine light. Lightly grease the 'O' rings. When fitting a new lamp make sure the lamp is switched off and bring the ignitor, lamp and reflector tube away and above the bilge to the highest point before changing the lamp.
- **Cautionary Label-"Caution: do not operate lights unless totally submerged" must be located by the main switch.**
After completing the installation procedure it is highly recommended to coat the face of the 'through-hull' submersible marine light with antifouling and bond them to the anodes or a cathodic protection system.
- **Power supply**
12 VOLT BALLAST- 12 volts DC- 6.4 amps. : **24 VOLT BALLAST-** 24 volts DC- 2.5amps
- **Note** a maximum of two lamps can be connected to one cable supply. The correct size cable must be used and the maximum volt drop (1.5 volts) on the cable length should be calculated using the maximum start up current.
- **LAMP CHANGE -** To change the lamp undo the 'grub screw' (3) and remove the 'reflector tube' (12). Insert the lamp into the 'lamp holder' (2) and replace the 'reflector tube' (2) and tighten the 'grub screw' (3).

underwater lights limited™

Part Description	Part No
1: Ballast 12 vdc 55 watt	95304
1: Ballast 24 vdc 55 watt	95305
2. Lamp Holder	95306
3. Grub screw	93308
4.'O' Ring (50mm)	02008
5: Xenon lamp 55 watt	91012
6: Adjustment screws	93335
7: Gasket	02009
8: Lens	02010
9: UL Ti MATE 80 Body	S02652-XT
10: Compensating ring	02602
11: Securing ring	02603-B
12: Reflector with tube	S02605-XT
13: Lamp holder securing ring	02608-A

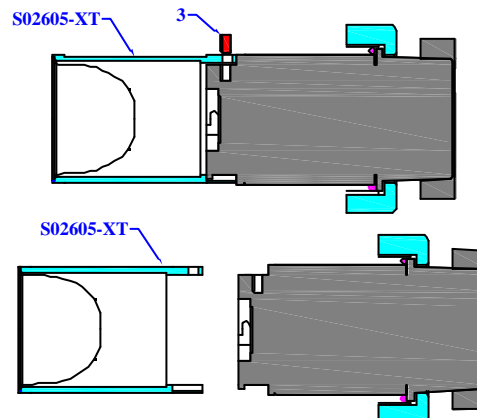
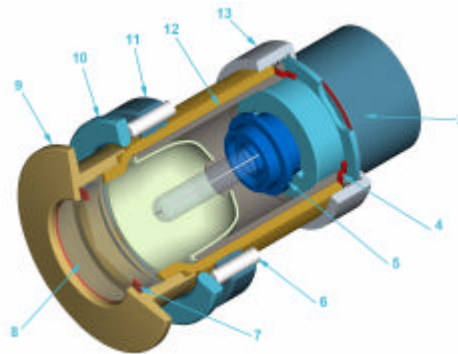

PLEASE REGISTER YOUR PRODUCT WARRANTY DIRECT TO WWW.REGISTER-UWL.COM
FOR TECHNICAL INFORMATION PLEASE EMAIL T@UNDERWATERLIGHTS.COM
SALES, PRODUCT INFORMATION AND NEWS GO TO WWW.UNDERWATERLIGHTS.COM

