

DECK LIGHT - MODEL NUMBER -S3052B-S3052S-S3052BF-S3052SF

underwater lights limited™

Manufacturers of the Original underwater lights™
Brand Marine Lighting Products since 1991

DESCRIPTION

This **Adjustable Light for Low/High Level Fitting** with a 4mm glass can be surface mounted, flush mounted using a weld-in insert and flush mounted using the deckhead insert.

It can be used for steps, walkways, deckheads and floodlighting.

The light is available with a bolted bezel for exposed areas or a screwed bezel for less exposed areas.

This light is also available as a fixed version with the same dimensions and specifications **Part No. S3052BF and S3052SF**

The bezel is manufactured from 316 Stainless Steel and is bolted or screwed to the stainless steel case. The light has been tested for water tightness to IP 66. The lamp is changed by removing the bezel.

TECHNICAL SPECIFICATION

Lamp type -MR 16 halogen

Voltage - 12v or 24v- Max 50w

IP Rating - IP 66

Glass lens finish - clear or frosted - 4mm

Bezel Finish - polished 316 stainless steel

Insert - Welded 30545 Alu./30546 S. Steel

Optional Integral Transformer -for 120/ 230v-60w

NOTE-

Installation Instruction-

For surface mounting the hole cut-out should be 68mm and the fixing screws are on a 76mm P.C.D.

For flush mounting into aluminium or steel plate use the weld-in insert. The hole is 110mm

For installation into **deckheads** that have a temperature rating of **max 65 deg**, the deckhead insert should be used. Please specify the deckhead thickness so the correct insert can be supplied.

For additional information please visit our web site.



Dimension for surface fitting

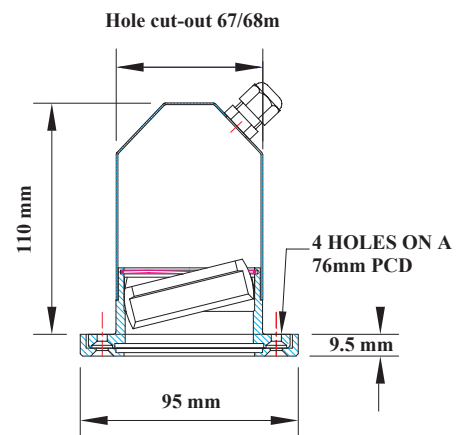

Dimension for flush deckhead fitting

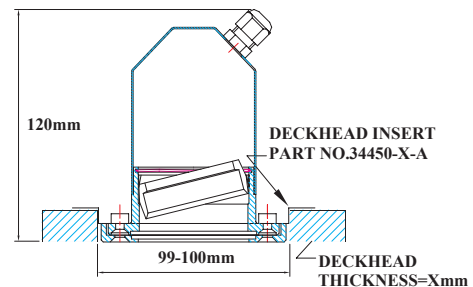

Dimension for flush weld-in fitting

